



**STROMBERG CARLSON  
PRODUCTS INC.**

CC-100 Instructions **NOTE: Not intended to be used for MOPENDS or any other motorized vehicle all loads should be evenly distributed over the surface of the carrier.**

Thank you for purchasing the Stromberg Carlson Cargo Caddy. When assembled and used properly, this product will provide many years of trouble free service. This kit contains components and hardware for one complete Cargo Caddy (**NOTE: CLEVIS PIN AND RECEIVER HITCH NOT INCULDED**). Please read these instructions completely before assembly. Complete the following easy steps and you will be ready to use your Cargo Caddy.

**WARNING:**

- Do not exceed receiver hitch's tongue weight rating.
- Distribute weight evenly on platform
- Do not transport live animals; exhaust fumes may be fatal.
- The cargo caddy is not intended for transporting humans
- Do not carry loads wider or deeper than the Cargo Caddy.
- Do not carry flammable items on Cargo Caddy.
- Do not cover vehicle's tail lights
- Do not allow exhaust fumes to blow directly on items. **This is a FIRE HAZARD.**
- Stromberg Carlson is not responsible for any damage if warnings are not heeded.

**Parts List:**

**Item# 1: (2) Platform halves**

**Item#2: (2) 4-hole plates**

**Item#3 (1) Receiver bar 2"**

**(If you need a 1.25" purchase a hitch reducer from you dealer)**

**Item #4 (2) Channel braces**

**Item #5 (2) Support bridges**

Tools you will need: **Two crescent wrenches**

**Hardware (included):**

**(8) Short carriage bolts**

**(4) Medium carriage bolts**

**(3) Long carriage bolts**

**(15) Lock nuts**

Part Lists

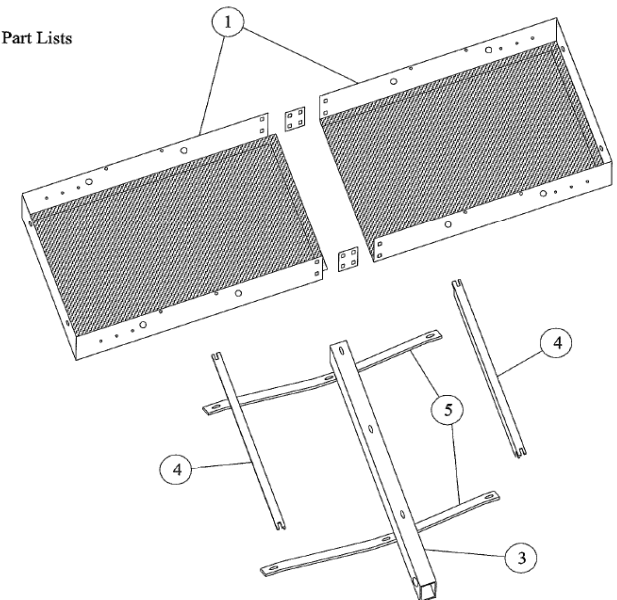

## Assembly instructions:

First, join the two sections of the platform halves together.

Then place 4-hole plates over both platform halves and use short carriage bolts and lock nuts to secure the platforms together. (see fig A)

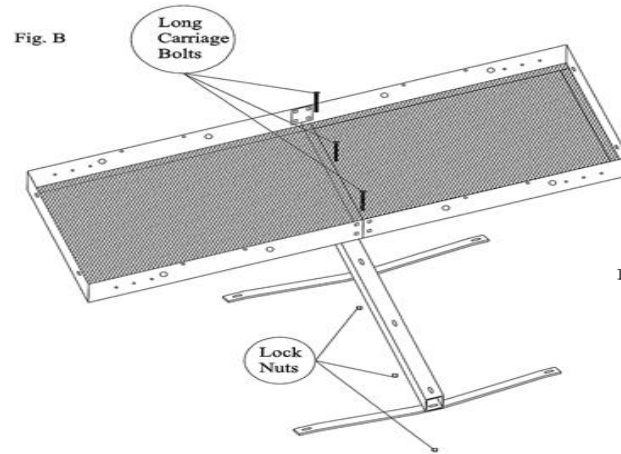
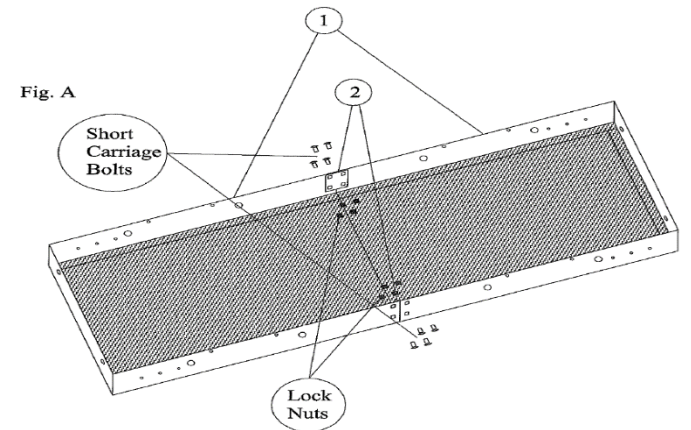

Next, use 3 long carriage bolts and 3 lock nuts to assemble platform to receiver bar and support bridges (platform assembly to items #3 & #5) (see fig B)

Then use 4 medium carriage bolts and 4 lock nuts to assemble channel braces (item #4) and the support bridges (item #5) to the platform. (see fig C)

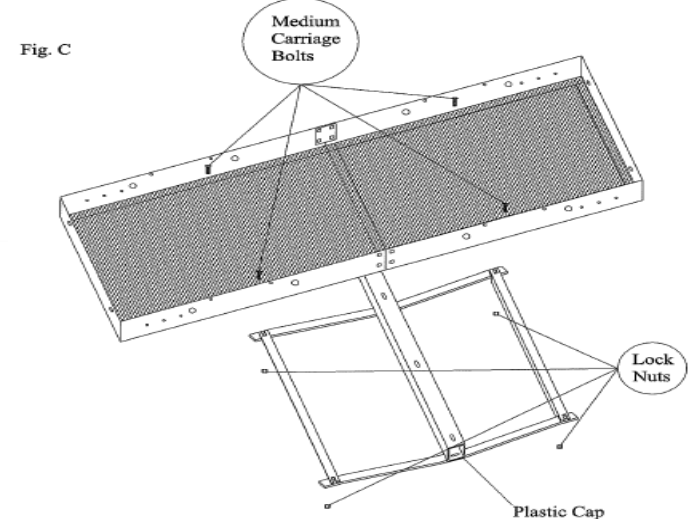

Install plastic receiver cap into open end of receiver bar that faces away from vehicle. Then install platform to your vehicle by sliding receiver tube into vehicle's receiver hitch. Clevis pin must slide through receiver hitch and receiver tube hole at the same time to secure cargo caddy properly. Place retainer clip through clevis pin.

As noted at the beginning of the instructions: CLEVIS PIN AND RECEIVER HTICH NOT INCULDED.